



# Matrox Morphis >>

Cost-effective family of boards for standard video capture and/or real-time JPEG2000 compression/decompression<sup>1</sup>.



## Key features

- ▶ PCIe® x1, PCI (-X<sup>2</sup>) or PCI-104 form factor
- ▶ captures from NTSC, PAL, RS-170 and CCIR video sources
- ▶ dual/quad video decoder architecture for ultra-fast channel switching
- ▶ connect and switch between up to 16 CVBS, up to 8 Y/C or a combination of inputs
- ▶ two trigger inputs<sup>1</sup>
- ▶ real-time JPEG2000 image compression and decompression<sup>1</sup>
- ▶ 16 TTL auxiliary I/Os and RS-485 serial interface
- ▶ watchdog timer for monitoring overall system integrity
- ▶ programmed using Matrox Imaging Library (MIL) sold separately
- ▶ supports 32/64-bit Microsoft® Windows® XP/Vista® and 32/64-bit Linux®

## Versatile design

Matrox Morphis is a family of cost-effective peripheral boards based on a truly versatile design. As a frame grabber board, the Matrox Morphis is ideal for video surveillance applications that require sequential capture from multiple standard sources with minimum latency. A modular design and simple standard connections provide additional flexibility and cost savings for video surveillance applications that require a scalable number of inputs. A real-time standard image compression and decompression accelerator for video archiving and/or transmission further qualifies Matrox Morphis for video surveillance applications. As an image compression and decompression board, Matrox Morphis is perfectly adapted for standard medical image archiving and transmission.

## Dual/quad video decoder architecture

An elaborate and finely tuned design featuring up to four video decoders working in tandem enables Matrox Morphis to rapidly switch between multiple video sources for sequential capture. The design also allows for the simultaneous capture from up to four independent standard video sources. A large dedicated buffer guarantees reliable image capture to the on-board compression accelerator<sup>1</sup> or the host PC, including display. Moreover, video images can be formatted in real-time during capture. Formatting features include cropping (ROI), horizontal and/or vertical flipping and subsampling.

## Real-time JPEG2000<sup>1</sup>

Matrox Morphis integrates a hardware accelerator for JPEG2000 image compression and decompression. JPEG2000 is an industry standard from the Joint Photographic Experts Group for wavelet-based compression and decompression. This new standard was developed to provide a superior compression ratio without compromising quality, or superior quality at a given compression ratio when compared to conventional JPEG. An intricate algorithm makes JPEG2000 computationally intensive, so hardware acceleration is required for real-time performance at typical video rates. For video surveillance applications, the JPEG2000 hardware accelerator can handle up to two standard video streams, whether monochrome or color, in lossy or lossless mode. It can also handle high resolution monochrome formats with high dynamic range found in medical imaging applications.



## Matrox Morphis Dual/eDual

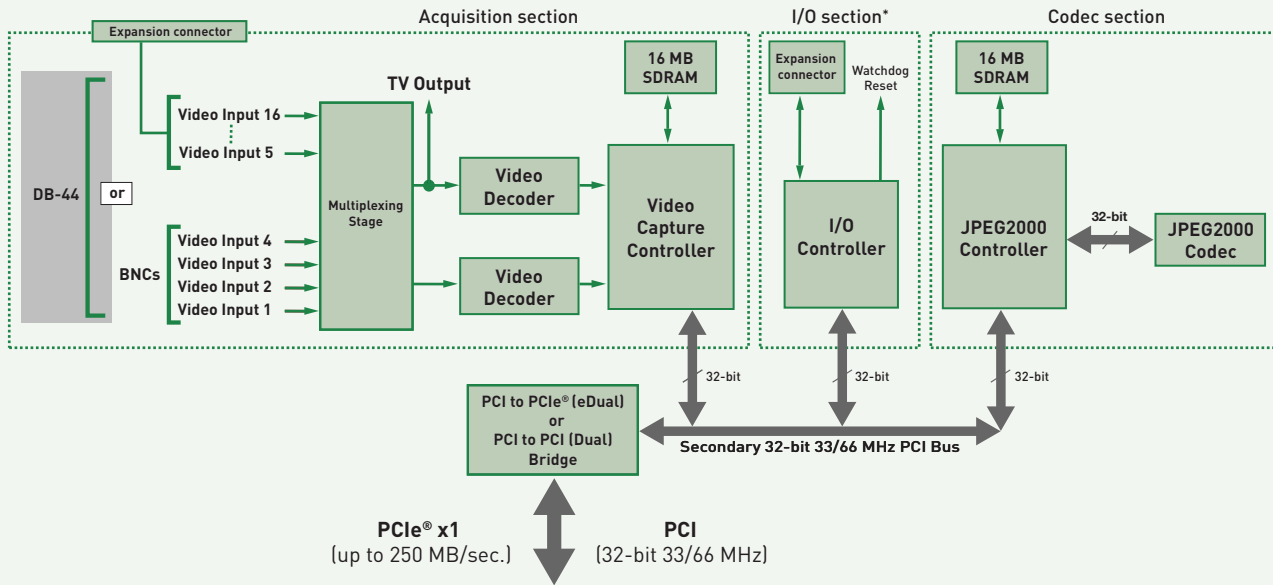

\* Not available on PCI-104 version.

## Matrox Morphis Quad/eQuad

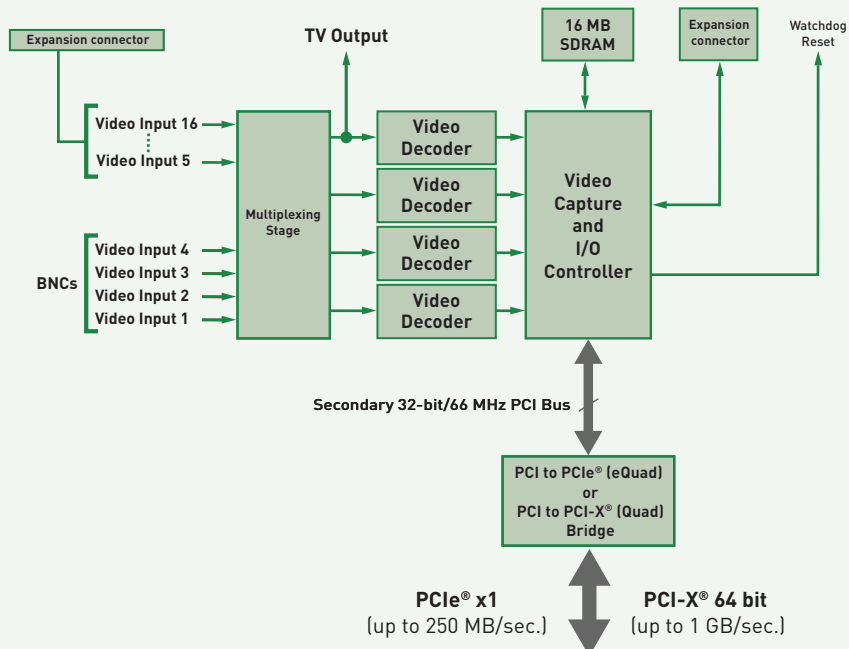

## ➤ Expansion modules for Matrox Morphis Dual/eDual or Quad/eQuad\*

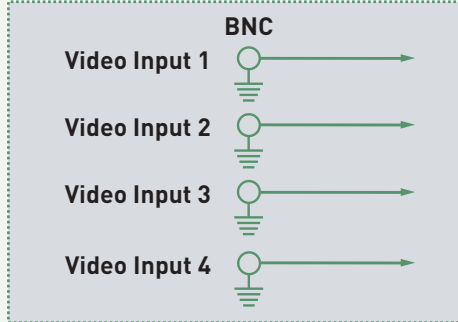

Composite Video Input module<sup>3</sup>

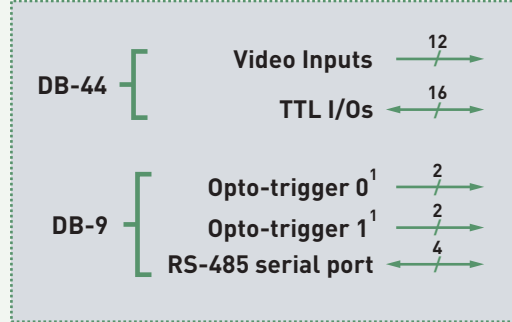

I/O module

\* Expansion modules use additional PC brackets

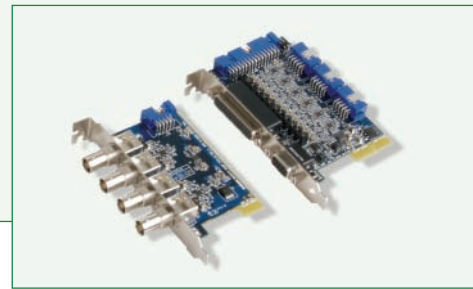

### Accessory functionality<sup>4</sup>

In addition to the core video capture and compression/decompression functionality<sup>1</sup>, Matrox Morphis incorporates a variety of features to simplify overall integration. These features include an integrated watchdog timer<sup>4</sup> for automatically recovering from application or system failure, integrated auxiliary I/Os<sup>4</sup> that eliminate the need for a separate I/O board, and an RS-485 serial interface<sup>4</sup> mapped as a PC COM port that can be accessed through the Win32<sup>®</sup> API.

### Field-proven application development software

Matrox Morphis is supported by the Matrox Imaging Library (MIL), a comprehensive collection of software tools for developing industrial imaging applications. MIL features interactive software and programming functions for image capture, processing, analysis, annotation, display and archiving. These tools are designed to enhance productivity, thereby reducing the time and effort required to bring your solution to market. Refer to the MIL datasheet for more information.

### Specifications

#### Acquisition

- analog composite (CVBS) or Y/C NTSC/PAL
- analog RS-170/CCIR
- dual/quad video decoder video architecture for
  - ultra-fast switching between multiple video sources
  - simultaneous capture from two/four independent video sources
- square pixel digitization
- input cropping (ROI capture)
- horizontal and/or vertical flip
- subsampling to 1/16th of a field or frame
- controllable automatic gain control (freeze with manual adjust)
- BGR32 packed, BGR24 packed, RGB planar, YUV422 packed and MON08 pixel formats
- opto-isolated trigger inputs (synchronized to video)<sup>1,5</sup>
- connect up to 16 CVBS or 8 Y/C or combination

#### Compression/decompression<sup>1</sup>

- JPEG2000 compression/decompression
- supports lossy (9/7 wavelet) and lossless (5/3 wavelet) modes
- handles monochrome (up to 12-bits per pixel) and color (YUV422) images/video
- manages large images (i.e., greater than 1k x 1k) using tiles
- programmable quantization factor, target size and quality
- real-time performance including two standard video streams simultaneously

## Specifications (cont.)

### Host interface

- 32-bit 33/66 MHz PCI host interface for Matrox Morphis Dual, and 64-bit 33/66 MHz 5/3.3 V PCI and 64-bit 66/100/133 MHz PCI-X host interface for Matrox Morphis Quad
- universal 32-bit card edge connector for Matrox Morphis Dual and universal 64-bit card edge connector for Matrox Morphis Quad
- PCIe® x1 host interface for Matrox Morphis eDual and eQuad
- PCIe® x1 card for for Matrox Morphis eDual and eQuad
- interrupts for start and end of field, frame, and sequence capture

### Connectors

- BNCs or DB-44 for all composite video signals
- DB-44 and DB-9 for composite video inputs, Y/C inputs, TTL I/Os and RS-485 serial interface

### RS-485 interface<sup>4</sup>

- supports RX and TX signals
- half-duplex mode
- mapped as a PC COM port (visible to OS)

### Dimensions and environmental information

- MOR/2VD/J2K/84\*, MOR/2VD/84\*, MOR/2VD/HD/84\*, MOR/4VD/84\* and MOR/J2K/84\*: 16.7 cm L x 10.7 cm H (6.6" x 4.2")<sup>6</sup>
- MOR+/2VD/84\* 9.0 cm L x 9.6 cm H (3.5" x 3.78")<sup>6</sup>
- MOR-4COMP: 5.6 cm L x 9.1 cm H (2.2" x 3.6")<sup>6</sup>
- MOR-IO: 6.9 cm L x 10.7 cm H (2.7" x 4.2")<sup>6</sup>
- operating temperature: 0° C to 55° C (32° F to 131° F)
- relative humidity: up to 95% (non-condensing)
- FCC class B for PCI[-X<sup>2</sup>] and FCC class A for PCI-104
- CE class B for PCI[-X<sup>2</sup>] and CE class A for PCI-104
- RoHS-compliant

### Software drivers

- Matrox Imaging Library (MIL) drivers for 32/64-bit Microsoft® Windows® XP/Vista®
- MIL drivers for 32/64-bit Linux®

## Ordering Information

### Hardware

Part number	Description
MOR/4VD/84*	Standard analog color/monochrome PCI-X frame grabber with four video decoders. Video input through BNC connectors.
MOR4VDE/84*	Standard analog color/monochrome PCIe® x1 frame grabber with four video decoders. Video input through BNC connectors.
MOR/2VD/J2K/84*	Standard analog color/monochrome PCI frame grabber with two video decoders and integrated JPEG2000 accelerator. Video input through BNC connectors.
MOR/2VD/84*	Standard analog color/monochrome PCI frame grabber with two video decoders. Video input through BNC connectors.
MOR2VDE/84*	Standard analog color/monochrome PCIe® x1 frame grabber with two video decoders. Video input through BNC connectors.
MOR/2VD/HD/84*	Standard analog color/monochrome PCI frame grabber with two video decoders. Video input through HD-44 connector.
MOR/J2K*	JPEG2000 accelerator PCI board.
MORJ2KE*	JPEG2000 accelerator PCIe® x1 board.
MOR-4COMP*	Add-on module for 4 additional CVBS inputs.
MOR-IO*	Add-on module for 12 additional CVBS inputs or 6 Y/C, 16 TTL I/Os and RS-485 serial port.
MOR+/2VD/84*	Similar to MOR/2VD/84* but for PCI-104 form factor.

## Ordering Information (cont.)

### Software

Refer to MIL datasheet.

#### Notes:

1. Morphis Dual only.
2. Morphis Quad only.
3. Cannot be used with boards that have HD-44 connector (/HD).
4. Not available on PCI-104 version.
5. One per video decoder.
6. Dimension from bottom edge of goldfinger to top edge of board.

#### Corporate headquarters:

Matrox Electronic Systems Ltd.  
1055 St. Regis Blvd.  
Dorval, Quebec H9P 2T4  
Canada  
Tel: +1 (514) 685-2630  
Fax: +1 (514) 822-6273

For more information, please call: 1-800-804-6243 (toll free in North America) or (514) 822-6020  
or e-mail: [imaging.info@matrox.com](mailto:imaging.info@matrox.com) or <http://www.matrox.com/imaging>

**matrox**<sup>®</sup>

All trademarks by their respective owners are hereby acknowledged. Matrox Electronic Systems, Ltd. reserves the right to make changes in specifications at any time and without notice. The information furnished by Matrox Electronic Systems, Ltd. is believed to be accurate and reliable. However, no responsibility license is granted under any patents or patent rights of Matrox Electronic Systems, Ltd. Windows and Microsoft are trademarks of Microsoft Corporation. MMX and the MMX logo are registered trademarks of Intel Corporation. Printed in Canada, 2010/03/30. **51E-5316-D**