

Basler Lenses



- 5 Megapixel Lens – optimized for 1/2.5" sensors with resolution of 2.2 μm [230 lp/mm]
- Basler exclusive design
- Best match for latest sensor technology with small pixel pitch
- Maximum performance for demanding machine vision applications
- List price starting at 99 €

OVERVIEW

Get Perfectly Proportioned Performance With Basler Lenses

With CMOS sensors trending smaller and smaller over the past few years, how can you be sure you're taking advantage of the latest cost-saving advances in sensor technology? The answer is simple. Match the size of your lens to the size of your sensor with the new Basler series of high performance lenses.

Only Basler offers lenses that are optimally designed for Basler cameras with sensors sized < 1/2", e.g. 1/4" or 1/3". The sensor size our new lens series is optimized for is 1/2.5" (7.3 mm) – a range which accommodates nearly every standard machine vision application. The lenses deliver exceptionally high resolution of 5 Megapixels and facilitate a sharp image from the center of the frame to the corners. The lenses have a diameter of just 29 mm – affording you the same space efficiency of the ace camera. Best of all, Basler Lenses set a new standard in terms of price-performance ratio. Our high quality lens is priced significantly below existing market rates paired with Basler cameras, starting at just € 99. In addition to reducing your initial investment at the time of purchase, choosing a Basler Lens saves you transaction costs by eliminating one additional vendor in your supply chain.

Basler Lenses are optimized for a working distance of 0.5 m to deliver the highest quality image in common machine vision applications. To make it even easier for the user to obtain the best image, we marked the ideal aperture of the lenses with an orange dot. Basler Lenses come with locking screws for the focus and iris ring. This makes them suitable for highly demanding machine vision applications with vibrations or acceleration.

Designed in cooperation with Fujinon, one of the world's premier optical technology firms with some 70 years of innovation to its credit, Basler Lenses are just one more way we're bringing the power of sight within reach of more customers within more industries, more easily than ever before.

Your benefits include:

- Exceptional high resolution to bring out the smallest details in your image
- Extraordinary price/performance ratio starting at € 99
- Optimized for working distances in typical machine vision applications
- Locking screws for focus and iris ring to withstand industry environment
- An orange dot on the iris ring indicates the optimal aperture to easily achieve the sharpest image
- Designed in cooperation with Fujinon, global leaders in optical manufacturing



TECHNICAL DETAILS

Specifications

Basler Lens	C125-0418-5M	C125-0618-5M	C125-0818-5M	C125-1218-5M	C125-1620-5M	C125-2522-5M
Lens						
Maximum image circle	1/2.5" (7.3 mm)					
Mount	C-Mount					
Focal Length	4 mm	6 mm	8 mm	12 mm	16 mm	25 mm
Maximum relative aperture	1:1.8			1:2.0		1:2.2
Iris range	F1.8 - F22				F2.0 - F22	F2.2 - F22
Focus range	0.1 m - ∞	0.1 m - ∞	0.1 m - ∞	0.2 m - ∞	0.2 m - ∞	0.2 m - ∞
Focus control	manual					
Iris control	manual					
Angle of view, horizontal/vertical, 1/2.5"	76.4°/58.5°	53.1°/40.1°	39.6°/29.9°	27.0°/20.3°	20.3°/15.3°	13.0°/ 9.8°
Angle of view, horizontal/vertical, 1/3"	66.0°/49.9°	45.5°/34.1°	33.9°/25.4°	23.1°/ 17.2°	17.3°/12.9°	11.1°/ 8.3°
Wavelength range	400 - 700 nm					
TV Distortion	-5,9%	-3,3%	-1,6%	-0,7%	-0,3%	-0,2%
Filter size	M46×0.75*	M35.5×0.5*		M25.5×0.5		
Dimensions	31.3×Ø29mm	30.6×Ø29mm	29.8×Ø29mm	40.8×Ø29mm	41.2×Ø29mm	41.0×Ø29mm
Weight	55g		65g		60g	
Operating temperature	-10°C to +50°C (14°F to 122°F)					

Specifications are subject to change without prior notice. Latest specifications can be found on our website www.baslerweb.com/Basler-Lenses

* filter adapter required

Dimensions (in mm)

Basler Lens with f = 4 mm, 6 mm, 8 mm

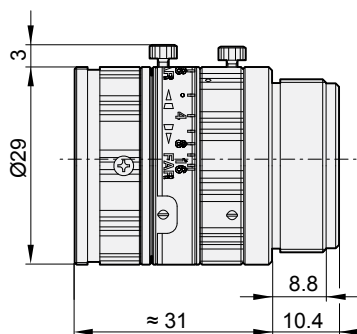

Basler Lens with f = 12 mm, 16 mm, 25 mm

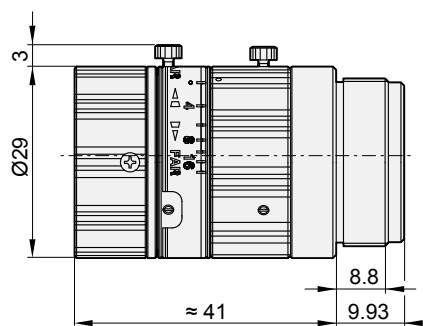

TECHNICAL DETAILS

Comparison Images

The following test images show the resolution of the Basler Lens compared to two competitor lenses.

Why is resolution such an important indicator for the performance of a lens?
The resolution controls the amount of detail visible in the image. To achieve a high-quality image throughout the entire field of view, the resolution must be excellent from center to corners.

CENTER OF 1/2.5" SENSOR

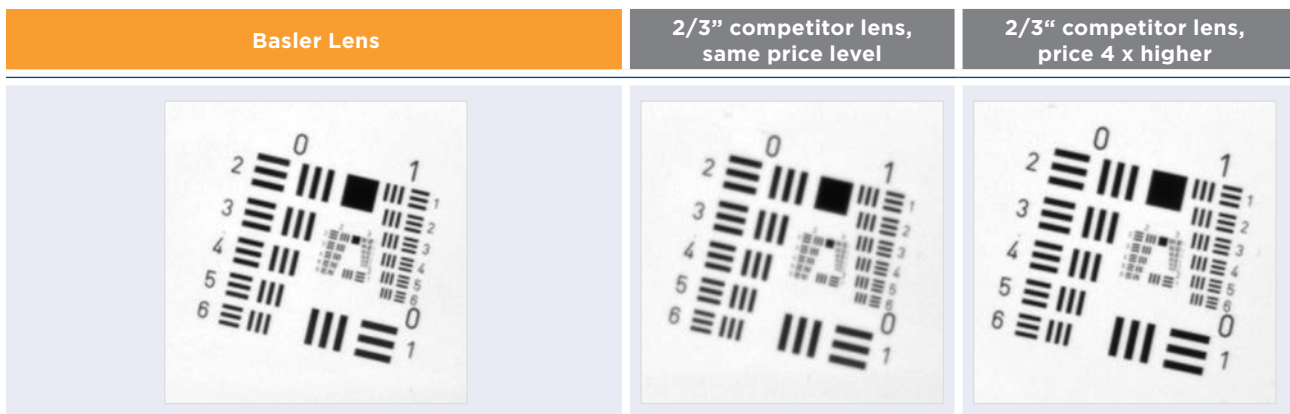

CORNER OF 1/2.5" SENSOR

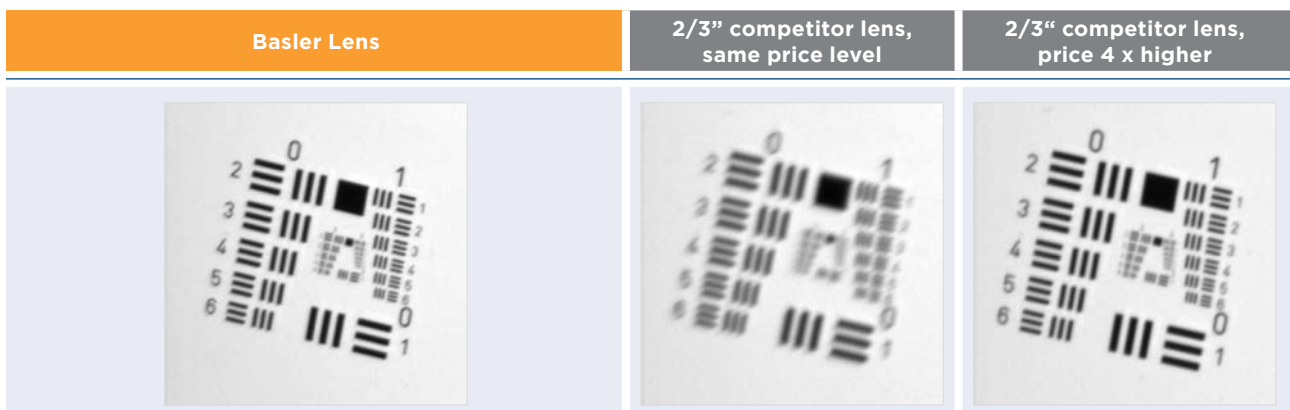

Test set-up:

Camera: acA2500-14gm (sensor: 5MP - MT9P031, pixel size 2.2 μ m)
Focal length of lenses: 8 mm
Test conditions: F# 2.8, exposure time 2.8 ms

OTHER INFORMATION

3-Year Warranty

Basler offers a 3-year warranty for their cameras and Basler Lenses. We make this unprecedented promise because we have unparalleled confidence in our products. We continually reinvest in research, development and superior manufacturing capabilities so that our customers can fully rely on the products we manufacture.

About Basler

Founded in 1988, Basler is a leading global manufacturer of high quality digital cameras and lenses for factory automation, medical & life sciences, and traffic applications. The company employs almost 500 people at its headquarters in Ahrensburg, Germany and subsidiaries in the United States and Asia.

Basler's portfolio of products offers customers the vision industry's widest selection of industrial and network cameras as well as lenses. Today it includes some 300 camera models - and it's still growing. We're committed to developing technology that drives business results for our customers: cameras and lenses that are easy to use, easy to integrate, and deliver an exceptional price/performance ratio.



Basler AG

Germany, Headquarters

Tel. +49 4102 463 500
Fax +49 4102 463 599
sales.europe@baslerweb.com
www.baslerweb.com

USA

Tel. +1 610 280 0171
Fax +1 610 280 7608
sales.usa@baslerweb.com

Singapore

Tel. +65 6367 1355
Fax +65 6367 1255
sales.asia@baslerweb.com

Taiwan

Tel. +886 3 558 3955
Fax +886 3 558 3956
sales.taiwan@baslerweb.com

China (Shanghai)

Tel. +86 21 6230 2160
Fax +86 21 6230 0251
sales.china@baslerweb.com

China (Shenzhen)

Tel. +86 181 2395 6667
Fax +86 21 6230 0251
sales.china@baslerweb.com

Korea

Tel. +82 70 7136 3114
Fax +82 70 7016 2705
sales.korea@baslerweb.com