

BL168 LENGTH MATRIX

PART #	LENGTH IN INCHES (mm)
BL16806	6.0 (152 mm)
BL16812	12.0 (305 mm)
BL16818	18.0 (457 mm)
BL16824	24.0 (610 mm)
BL16830	30.0 (762 mm)
BL16836	36.0 (914 mm)
6" INCREMENTS UP TO MAX OF 90"	

REVISIONS			
REV.	DESCRIPTION	DATE	DCN NO
-	FOR QUOTING PURPOSES ONLY		

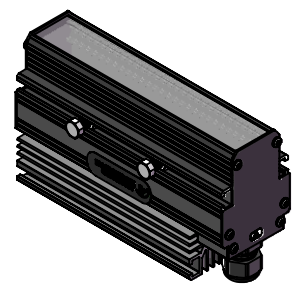
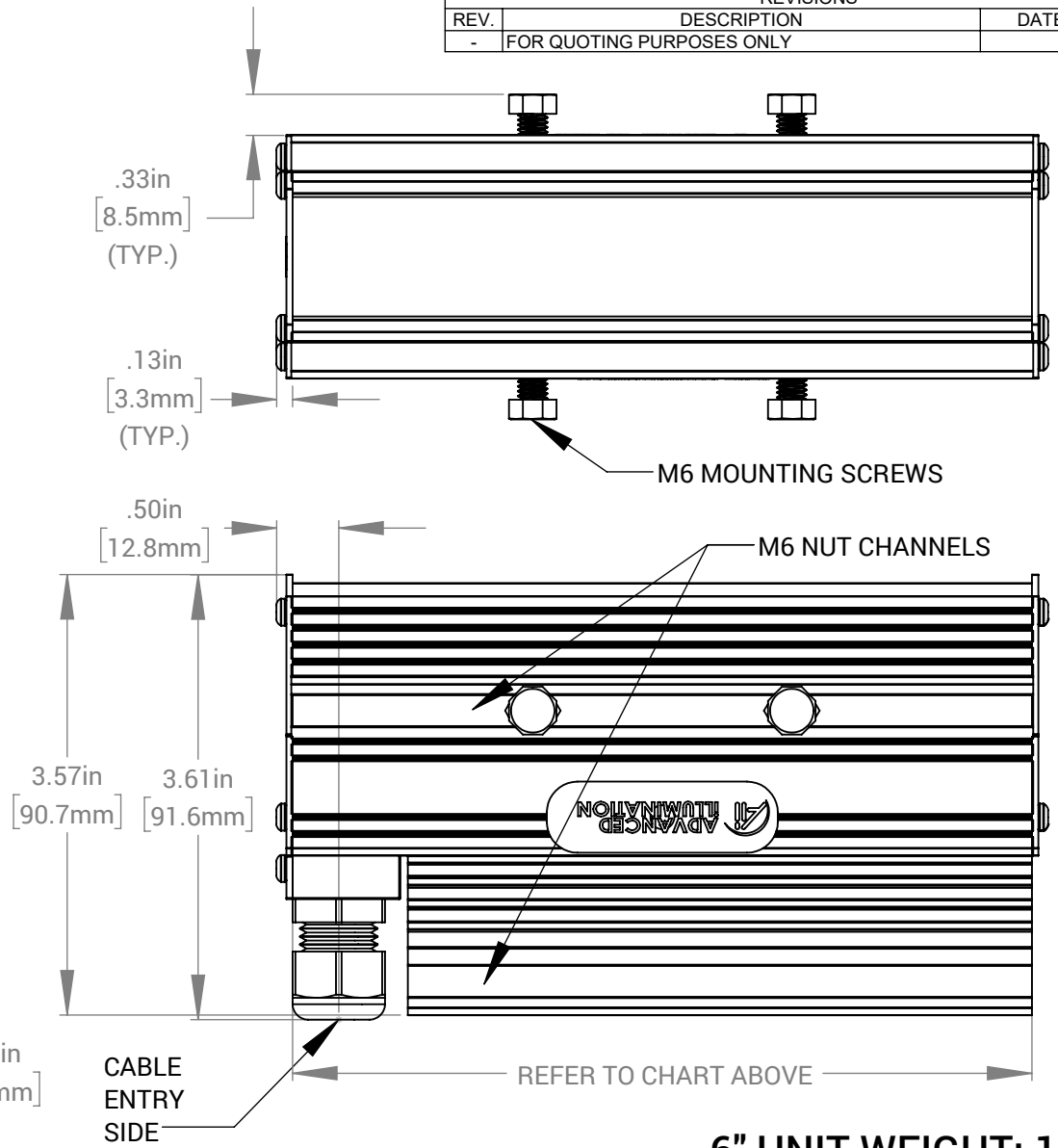
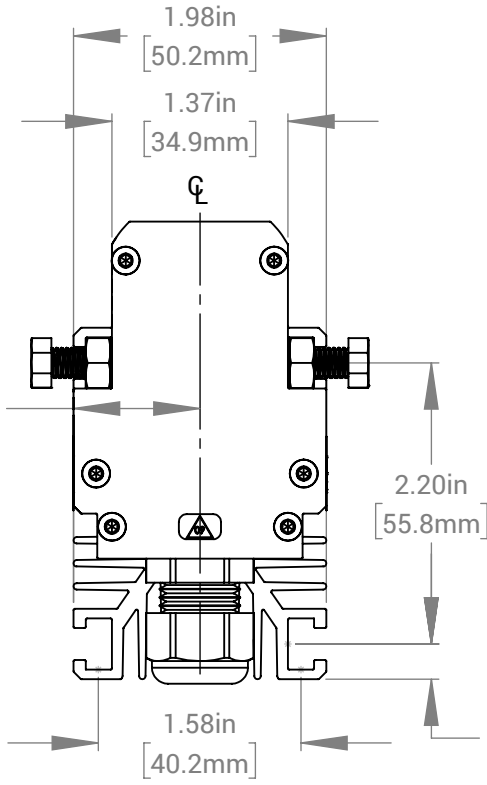

FOR REFERENCE ONLY

PROPRIETARY AND CONFIDENTIAL
 THESE DRAWINGS AND SPECIFICATIONS ARE THE EXCLUSIVE PROPERTIES OF ADVANCED ILLUMINATION INCORPORATED ISSUED IN STRICT CONFIDENCE AND SHALL NOT, WITHOUT THE PRIOR WRITTEN PERMISSION OF ADVANCED ILLUMINATION INC BE REPRODUCED, COPIED OR USED FOR ANY PURPOSE WHATSOEVER EXCEPT THE MANUFACTURE OF ARTICLES FOR ADVANCED ILLUMINATION INC

6" UNIT WEIGHT: 1.4 lbs

CUT USING: -	UNLESS OTHERWISE SPECIFIED: SURFACE SHOULD BE FREE OF SCRATCHES, BURRS, AND DENTS DIMENSIONS ARE IN: INCHES <u>TOLERANCES</u> FRACTIONAL: 1/16 ANGULAR: MACH ± 1 BEND ± 1 TWO PLACE DECIMAL ± .010 THREE PLACE DECIMAL ± .005 MAKE FROM	DRAWN CHECKED APPROVED MATERIAL FINISH	DATE 23-JAN-15	NAME J. BOWEN	<p>440 STATE GARAGE ROAD, ROCHESTER, VERMONT 05767</p>
NEXT ASSY	USED ON	TITLE: DRAWING, INSTALLATION, 168			
APPLICATION		SIZE A	DWG. NO. BL168	REV -	
SCALE: NTS C CODE: -			SHEET 1 OF 1		