

This sheet is property of ADIMEC. Reproduction, utilization or disclosure to third parties in any form whatsoever is not allowed without written consent of the proprietors

LM-C-ST154

AIS-A3-P-SKT Revision 1.0

Copyright ADIMEC Advanced Image Systems B.V.

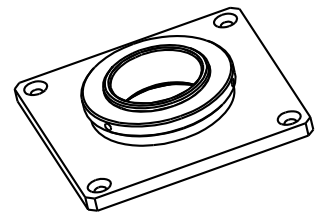
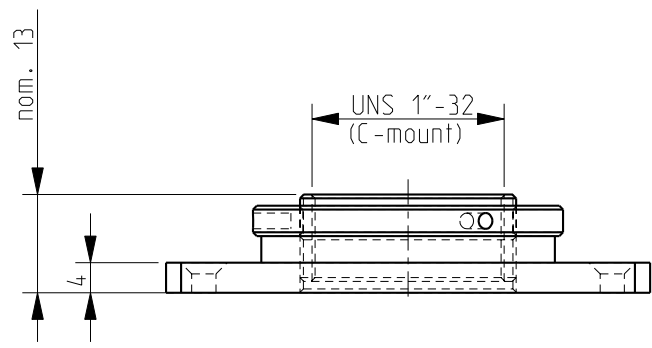
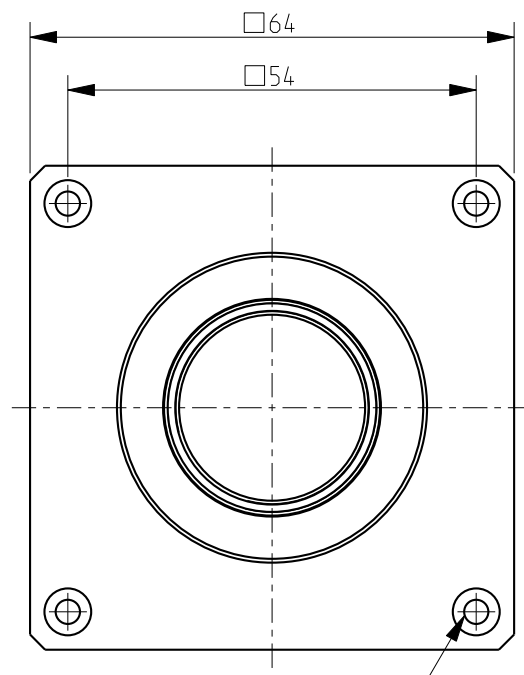

SCALE 0.500

* Use 3D STEP-file for dimensions that are not shown on this drawing.
 * See tolerance for general deviation from nominal 3D STEP-file.
 * Dimensions on drawing are applicable after surface treatment(s).

Rev.	Changed by	Description	Zone	Date

Drawn by M. de Jong	Sign	Reviewer	Date	Sign	Reviewer	Date	Sign	PM	Date	Sign	
Project -	Number 173480-110-20190218			Draft date							
Title LENSMOUNT-C-54-ADJ		Tolerance unless otherwise specified Dim. ±0.1 Angle ±1° Radi ±0.3				Shape & position tolerances according to n.a.					
Company Adimec		Material Aluminium			Roughness according to n.a.		Sheet 1 / 1		Units unless otherwise specified mm		Scale 1.000
Treatment Optical matt black		Projection 		Size A4							
3			2			1					