

Interfacing Matrox hardware to CCS Light Sequence Switch

Overview

This application note describes how to interface a [CCS Light Sequence Switch \(LSS\)](#) to a Matrox Iris GTR smart camera, Matrox 4Sight GpM/EV6 vision controller and Matrox Indio card henceforth referred to as Matrox hardware unless stated otherwise.

Initial trigger source

A LSS requires an initial trigger to start an illumination sequence. This initial trigger can come directly from a photoelectric or equivalent sensor (Figure 1).



Note that the LSS's Trigger Polarity must be set to Negative and the Trigger Level to 2.5V to work with Matrox hardware.

Figure 1 - Initial trigger from a photoelectric or equivalent sensor.

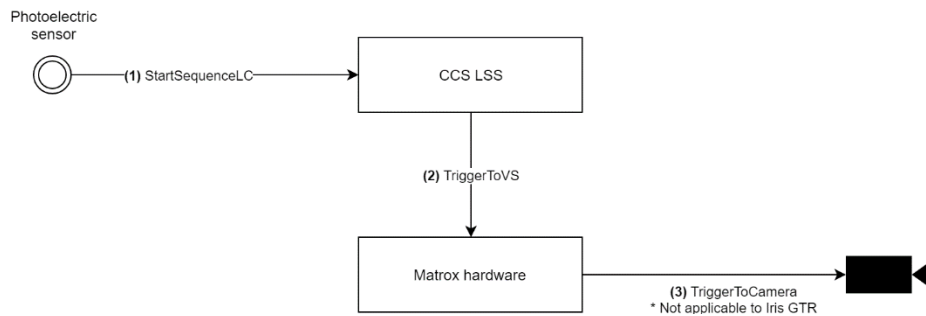

The initial trigger can also come from an automation controller or PLC. In this case, the vision system will have to detect a change to the appropriate PLC field (over the network link using the CC-Link IE Field Basic, EtherNet/IP or PROFINET protocols). Once the PLC field change is detected, the Matrox hardware will need to be instructed to set one of its discrete outputs to trigger the LSS (Figure 2).

Figure 2 – Initial trigger from a PLC via Matrox hardware.

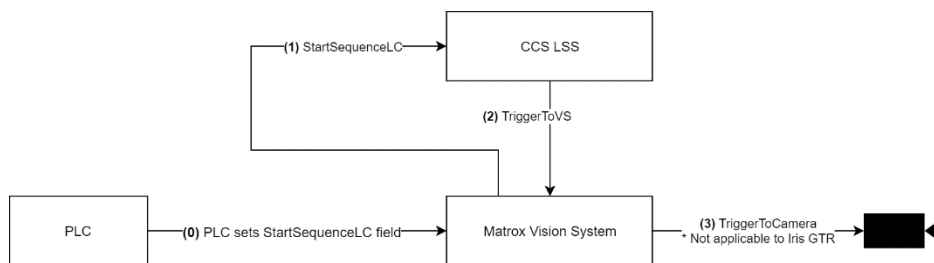

Note that the Matrox Design Assistant PhotometricStereo example projects already have the necessary fields and events defined for working with a PLC. One simply needs to enable either the CC-Link IE Field Basic, EtherNet/IP or PROFINET protocols to use any of the example projects with a PLC. A trigger pulse

Interfacing Matrox hardware to CCS Light Sequence Switch

will be sent to the LLS over the specified discrete output when the StartSequenceLC field changes from 0 to 1.

Timing diagram

Figure 3 illustrates the signal timing sequence between a LSS, Matrox hardware and a third-party camera, when relevant. In addition, the timing sequence is described as follows:

1. A signal is sent to the LSS to initiate the illumination sequence.
2. The LSS turns on the next illumination sector and then sends a trigger to the vision system to capture an image.
3. A trigger signal is sent to the camera to capture an image. Note: This signal is not needed when using a Matrox smart camera.

Steps 2 and 3 are repeated for all the selected illumination sectors.

Figure 3 - Signal timing diagram.

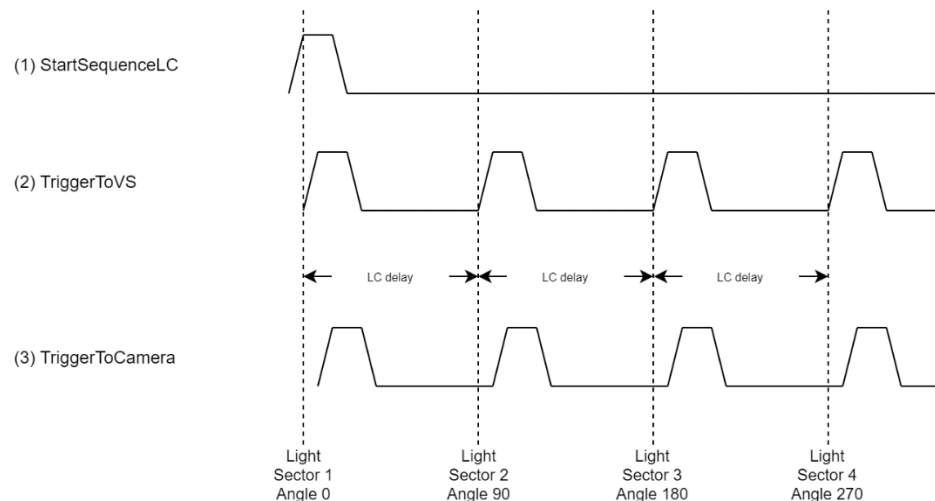

Interfacing Matrox hardware to CCS Light Sequence Switch

The LC delay, which is the LSS's Frame Time, needs to take into account the image capture time:

- The camera's exposure delay
- The camera's exposure time
- The camera's image readout time, which is often 1 over the camera's maximum frame rate

This delay can be calculated as follows:

$$LC\ delay \cong Exposure\ Delay + Exposure\ Time + Image\ Readout\ Time$$



The LSS needs to be set for just four (4) sequences with each quadrant turned on in turn (i.e., Sequence 1: Q1 on, Q2-Q4 off; ...; Sequence 4: Q1-Q3 off, Q4 on) to work with the Matrox Design Assistant PhotometricStereo example projects.

Interfacing Matrox hardware to CCS Light Sequence Switch

Wiring diagrams

The following figures illustrate how to wire the various discrete trigger signals between the Matrox hardware, LSS and third-party camera, when relevant. Figure 4 does so for the Matrox Iris GTR smart camera, Figure 5 for the Matrox 4Sight GPM/EV6 vision controller and Figure 6 for the Matrox Indio card.

Figure 4 - Wiring between Iris GTR and LSS.

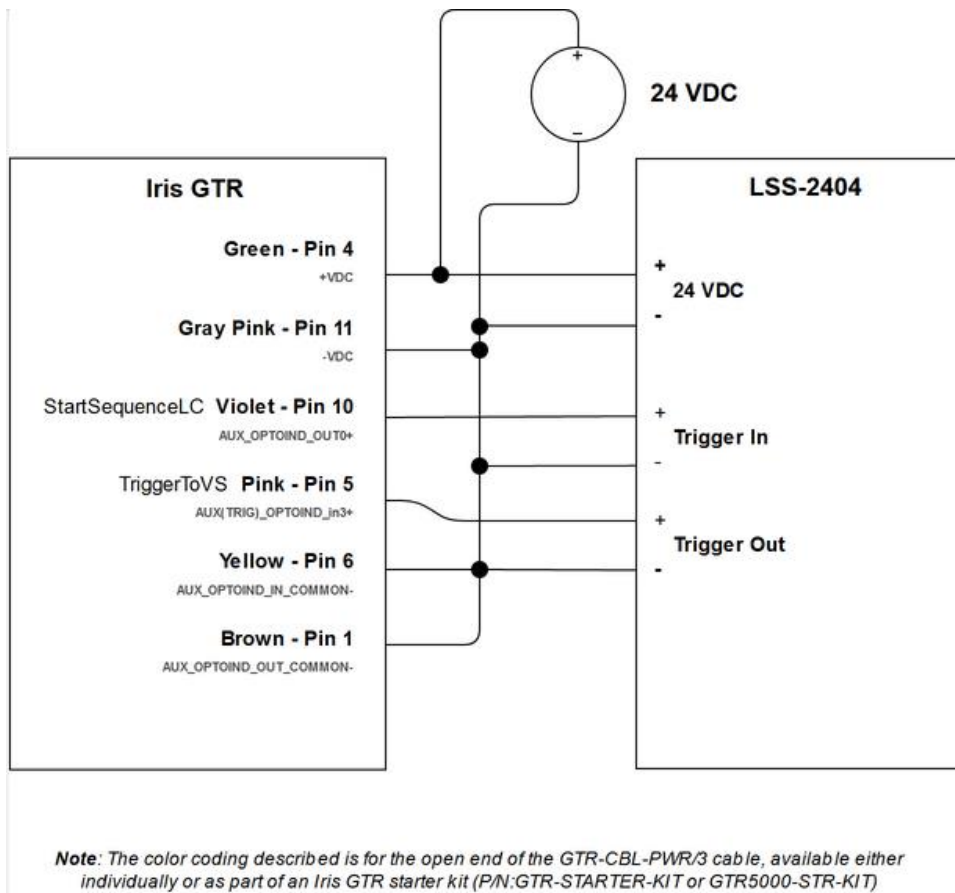

Interfacing Matrox hardware to CCS Light Sequence Switch

Figure 5 - Wiring between 4Sight GpM/EV6, LSS and third-party camera.

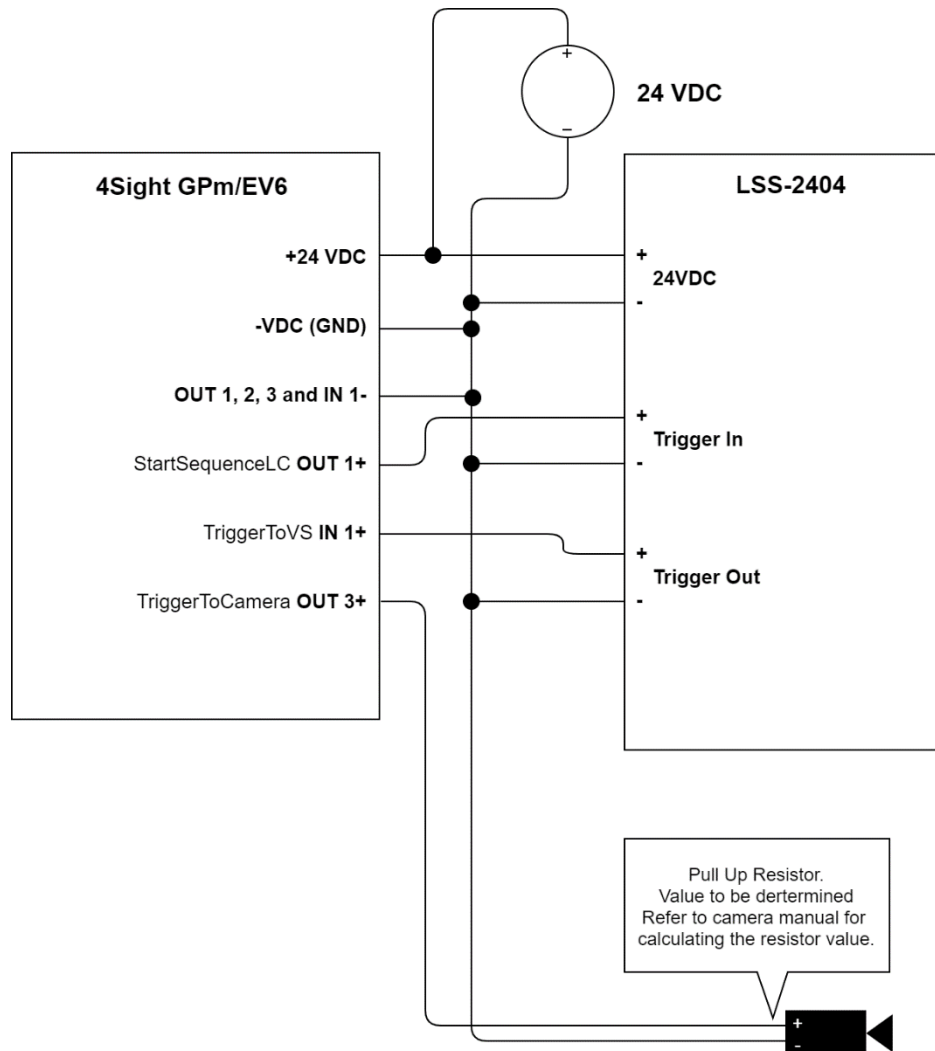

Interfacing Matrox hardware to CCS Light Sequence Switch

Figure 6 - Wiring between Indio, LSS and third-party camera.

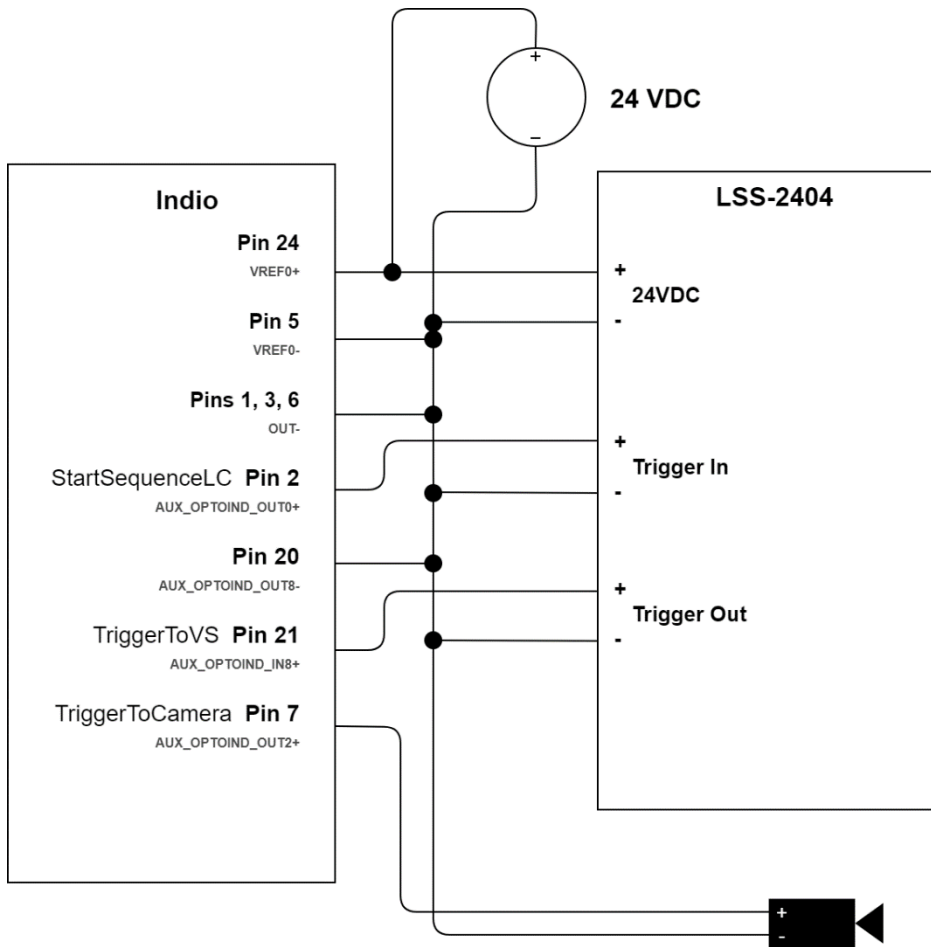

NOTES:

The Indio's on-board pullup circuitry for both inputs and outputs is assumed to be instantiated by way of the appropriate jumpers. Refer to the Indio's Installation and Hardware Reference manual for more information.

The TriggerToCamera polarity is to be set to falling edge because of Indio's on-board pullup circuitry.